



FROMM | WRAPPING
SOLUTIONS
www.fromm-stretch.com

FS360 Semi-Automatic Stretch Wrapping Machine

Economical alternative to hand wrapping:

FS360 STRETCH WRAPPING MACHINE is the simple entry level stretch wrapper for the user who needs to wrap pallets quickly, strongly and at a competitive price.

It can be equipped with different carriages.

Technical features:

- Standard pallet height up to 2100mm;
- Possible setting in lowest position of film carriage to wrap at turntable level;
- Belt driven carriage with safety system to prevent accidental falling;
- Safety foot protection;
- Audio signal at start of wrap cycle;
- Machine easy to move using a forklift truck;
- European quality and safety standards, including CE;

Power supply:

1 phase 230V 50/60Hz;
Working conditions + 5° up to + 45°C;

Machine options:

- Horseshoe turntable;
- Integrated weighing system;
- Printer for integrated weighing system;
- Access ramps;
- Access ramps for electric pallet truck;
- Frame for submerged floor mounting;
- Interchangeable photocell to detect black film and black product;
- Cutting device;

Space saving open turntable

The optional open turntable makes loading with a hand pallet truck easy, specially where floor space is limited. Equipped with an integrated walk-on safety device.

Film carriages:

- C1 Carriage with manual roll core brake to adjust film tension;
- C2 Carriage with manually adjustable single roll brake, to adjust film tension as required;
- C3 Carriage with one-motor pre-stretch and fixed gears - 150% or 200%. Film tension adjustable from control panel;
- Film roll dimensions: Core ø76 mm, Roll max. outside ø250 mm. Width 500mm;
- Film thicknesses: up to max. 35 µ;
- Photocell for pallet height detection;
- Frequency inverter controlled speed;



Moving the machine

Machine easy to move using a forklift truck;



Low bottom wrapping at turntable level

Possible setting in lowest position of film carriage to wrap at turntable level;



Horseshoe turntable with 3 in feed

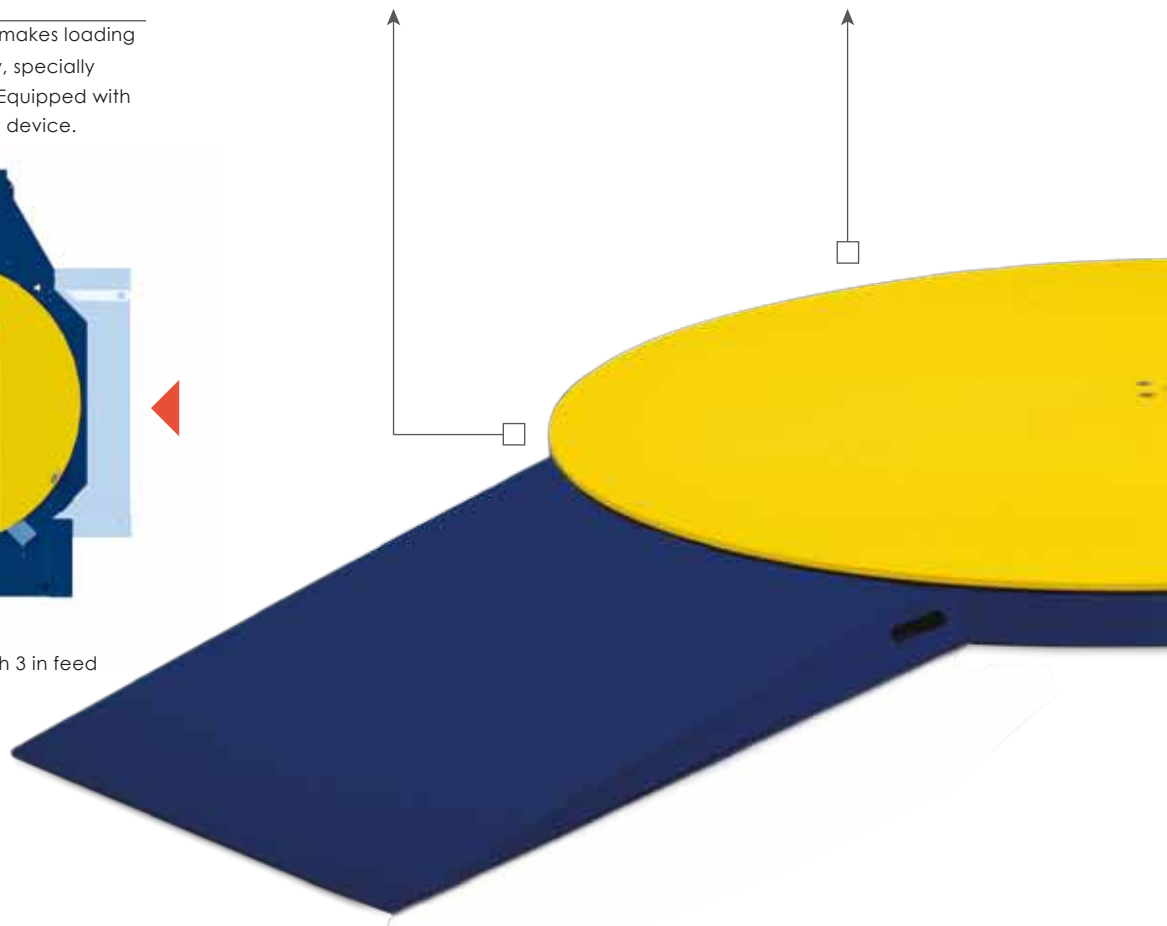



Control panel:

- Top and bottom wraps from 0 to 5;
- Double cycle (upward/downward);
- Single cycle (only upward);
- Manual mode;
- Table rotation speed from 6 to 12 rpm;
- Carriage speed adjustable from 2 to 4 m/min;
- Film tension adjustable (only available with one motor pre-stretch);



Turntables:

- Turntable Ø1500mm: maximum pallet format 800x1200mm (max. load weight 1500Kg);
- Turntable Ø1650mm: maximum pallet format 1100x1200mm (max. load weight 2000Kg);
- Soft start and soft stop in zero position;

New feature:

Turntable gearboxes with torque limiter.

Torque limiter helps to protect the gearbox from damaging effects caused by forced pallet movements on turntable.

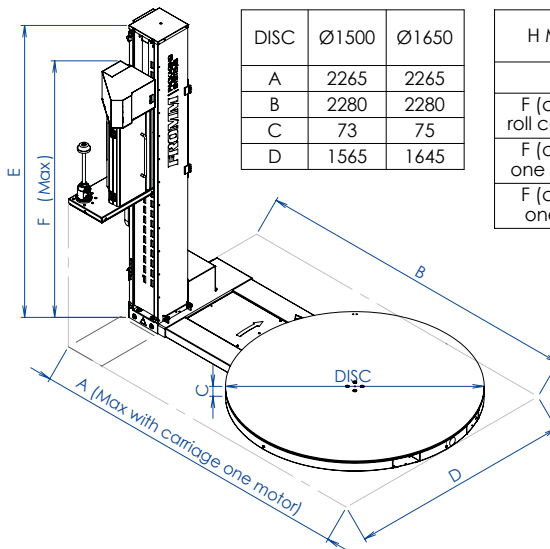

DISC	Ø1500	Ø1650
A	2265	2265
B	2280	2280
C	73	75
D	1565	1645

H Max Film	2100	2500
E	2060	2460
F (carriage roll core brake)	2270	2670
F (carriage one roll brake)	2350	2750
F (carriage one motor)	2460	2860

FS360 Semi-Automatic Stretch Wrapping Machine

The simple entry level stretch wrapping machine for the user who needs to wrap pallets quickly, strongly and at a competitive price.



Development centre in Germany



Production centre for machines and equipment in Italy



Production centre for STARstrap™ strapping in Thailand



Productions centre for STARstrap™ strapping in Germany



Productions centre for STARstrap™ strapping in Chile



Polyester recycling plant in Germany

FROMM Group

Established in 1947, the Swiss family business generates a turnover in excess of 180 million Euros and employs a workforce of 900 people worldwide. More than 40 subsidiaries in Europe, North and South America, South Africa, Asia and Australia, along with a multitude of specialized sales partners throughout the world ensure - in your vicinity - professional advice, prompt customer service and maintenance. The company pursues a policy of logical vertical integration while upholding traditional values, which are the reasons for decades of success.

Development centre

In the FROMM development centre, a long established and experienced team of engineers constantly develops new techniques and products using the very latest 3D CAD systems. Up-to-date test procedures guarantee the high FROMM quality standards.

Production centres for machines and equipment

Production takes place round the clock in the FROMM production centres.

Highly qualified teams of specialists manufacture FROMM products satisfying the highest demands of quality on computer-controlled machines. All machines are tested before leaving the factory. The company has ISO 9001 certification.

Production centres for polyester plastic strapping and multilayer blown films

STARstrap™ plastic strappings are produced in the FROMM production centres exclusively from recycled polyester bottle material on modern state-of-the-art extrusion plant. These bands guarantee the high quality of the strapping carried out with FROMM machines and equipment. All kinds of film types for the Airpad pillow material are produced on

blown film extrusion machines. Special film types guarantee a high loading capacity of the individual pillow elements. The plants are certified in accordance with ISO 9001 and ISO 14000.

Polyester recycling plant

Produced in the FROMM recycling plant from used PET bottles is high grade ground material, agglomerates and regranulates for the production of PET strapping, food-stuff films, textiles and drink bottles. This enables FROMM PET products to satisfy the most rigorous ecological requirements. The plant is certified in accordance with ISO 9001 and ISO 14000.

FROMM stands for development, production, consultancy, sales and service – worldwide and from a single supplier!

Benefit from our expertise!

